



Cambridge IGCSE™

CANDIDATE
NAME

--

CENTRE
NUMBER

--	--	--	--	--

CANDIDATE
NUMBER

--	--	--	--



ADDITIONAL MATHEMATICS

0606/12

Paper 1

October/November 2020

2 hours

You must answer on the question paper.

No additional materials are needed.

INSTRUCTIONS

- Answer **all** questions.
- Use a black or dark blue pen. You may use an HB pencil for any diagrams or graphs.
- Write your name, centre number and candidate number in the boxes at the top of the page.
- Write your answer to each question in the space provided.
- Do **not** use an erasable pen or correction fluid.
- Do **not** write on any bar codes.
- You should use a calculator where appropriate.
- You must show all necessary working clearly; no marks will be given for unsupported answers from a calculator.
- Give non-exact numerical answers correct to 3 significant figures, or 1 decimal place for angles in degrees, unless a different level of accuracy is specified in the question.

INFORMATION

- The total mark for this paper is 80.
- The number of marks for each question or part question is shown in brackets [].

This document has **16** pages. Blank pages are indicated.

- 1 The curve $y = 2x^2 + k + 4$ intersects the straight line $y = (k + 4)x$ at two distinct points. Find the possible values of k . [4]



2

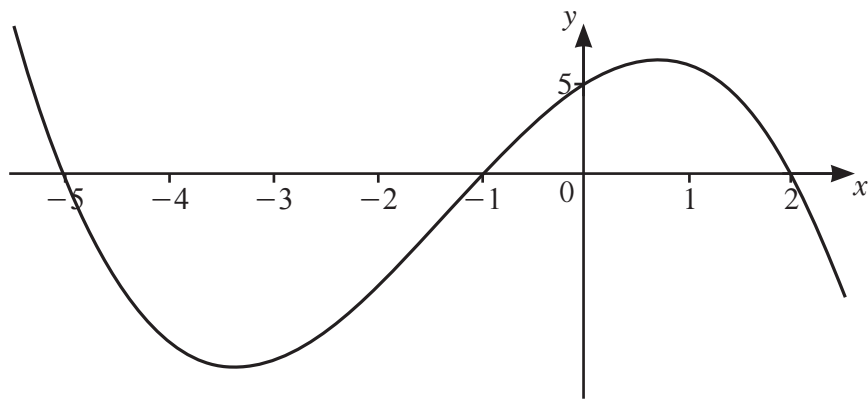

The diagram shows the graph of $y = f(x)$, where $f(x)$ is a cubic polynomial.

- (a) Find $f(x)$. [3]

- (b) Write down the values of x such that $f(x) < 0$. [2]

3 (a) Write down the amplitude of $2 \cos \frac{x}{3} - 1$. [1]
R

(b) Write down the period of $2 \cos \frac{x}{3} - 1$. [1]

(c) On the axes below, sketch the graph of $y = 2 \cos \frac{x}{3} - 1$ for $-\pi \leq x \leq 3\pi$ radians.

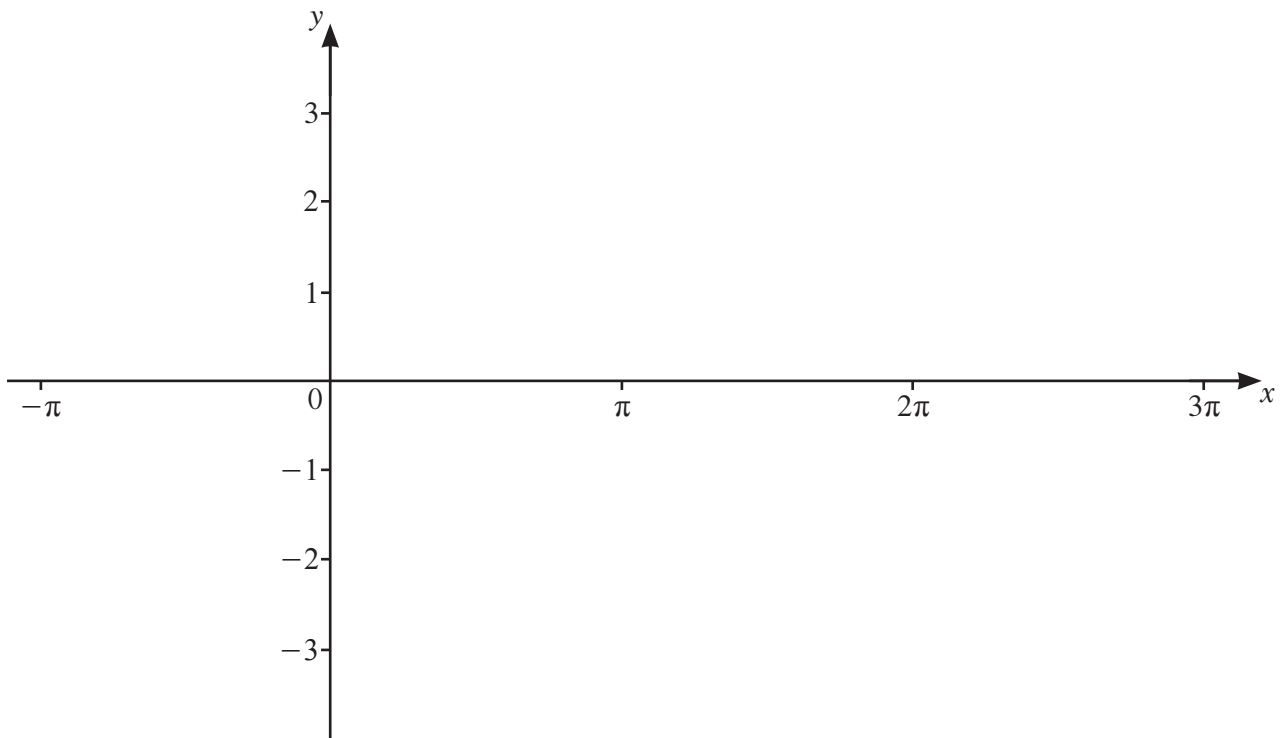

[3]

4 The 7th and 10th terms of an arithmetic progression are 158 and 149 respectively.



(a) Find the common difference and the first term of the progression.

[3]

(b) Find the least number of terms of the progression for their sum to be negative.

[3]

- 5 Find the coefficient of x^2 in the expansion of $\left(x - \frac{3}{x}\right)\left(x + \frac{2}{x}\right)^5$. [5]



6

$$f(x) = x^2 + 2x - 3 \quad \text{for } x \geq -1$$



- (a) Given that the minimum value of $x^2 + 2x - 3$ occurs when $x = -1$, explain why $f(x)$ has an inverse. [1]

- (b) On the axes below, sketch the graph of $y = f(x)$ and the graph of $y = f^{-1}(x)$. Label each graph and state the intercepts on the coordinate axes.

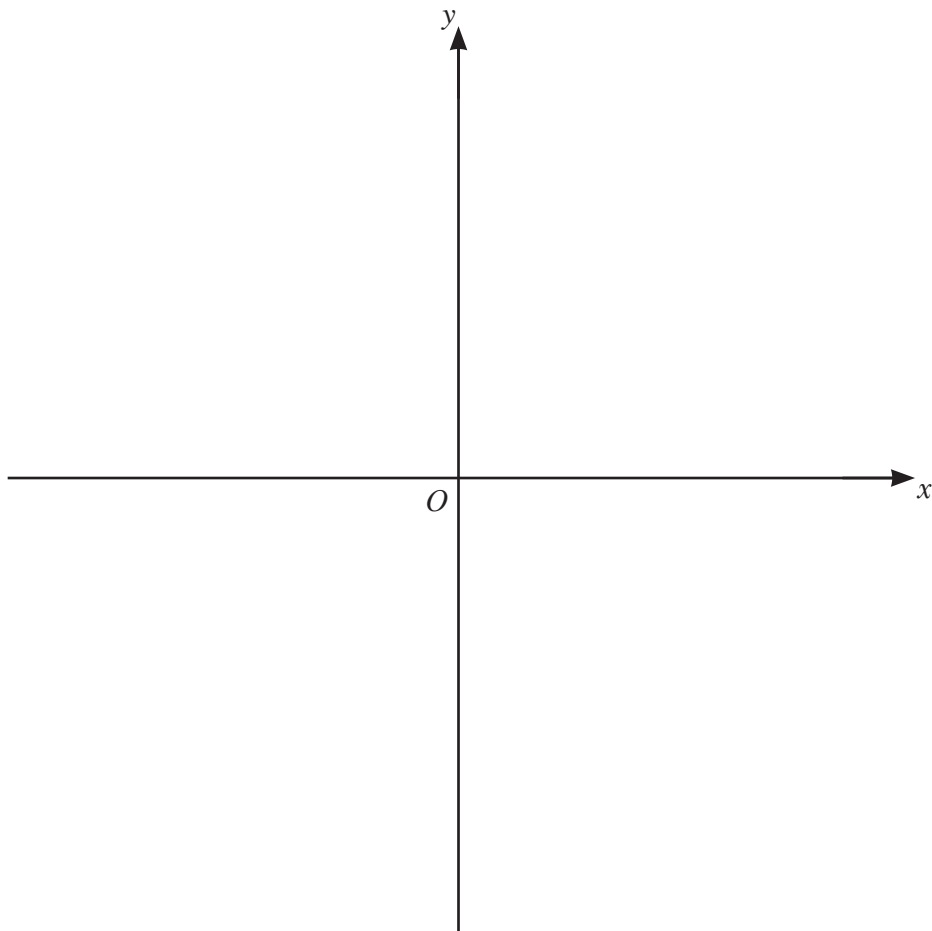

[4]

7 A curve has equation $y = \frac{\ln(3x^2 - 5)}{2x + 1}$ for $3x^2 > 5$.



(a) Find the equation of the normal to the curve at the point where $x = \sqrt{2}$.

[6]

(b) Find the approximate change in y as x increases from $\sqrt{2}$ to $\sqrt{2} + h$, where h is small.

[1]

- 8** (a) Find the number of ways in which 12 people can be put into 3 groups containing 3, 4 and 5 people respectively. [3]



- (b) 4-digit numbers are to be formed using four of the digits 2, 3, 7, 8 and 9. Each digit may be used once only in any 4-digit number. Find how many 4-digit numbers can be formed if

(i) there are no restrictions, [1]

(ii) the number is even, [1]

(iii) the number is greater than 7000 and odd. [3]

9 A curve has equation $y = (2x - 1)\sqrt{4x + 3}$.



(a) Show that $\frac{dy}{dx} = \frac{4(Ax + B)}{\sqrt{4x + 3}}$, where A and B are constants.

[5]

(b) Hence write down the x -coordinate of the stationary point of the curve.

[1]

(c) Determine the nature of this stationary point.

[2]

10 The polynomial $p(x) = 6x^3 + ax^2 + bx + 2$, where a and b are integers, has a factor of $x - 2$.



(a) Given that $p(1) = -2p(0)$, find the value of a and of b . [4]

(b) Using your values of a and b ,

(i) find the remainder when $p(x)$ is divided by $2x - 1$, [2]

(ii) factorise $p(x)$. [2]

11 In this question all lengths are in centimetres and all angles are in radians.

7

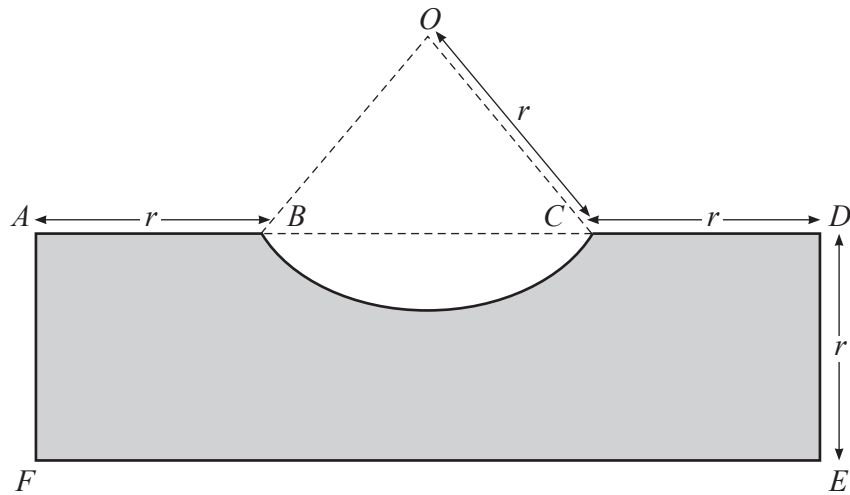

The diagram shows the rectangle $ADEF$, where $AF = DE = r$. The points B and C lie on AD such that $AB = CD = r$. The curve BC is an arc of the circle, centre O , radius r and has a length of $1.5r$.

(a) Show that the perimeter of the shaded region is $(7.5 + 2 \sin 0.75)r$. [5]

- (b) Find the area of the shaded region, giving your answer in the form kr^2 , where k is a constant correct to 2 decimal places. [4]

12 (a)

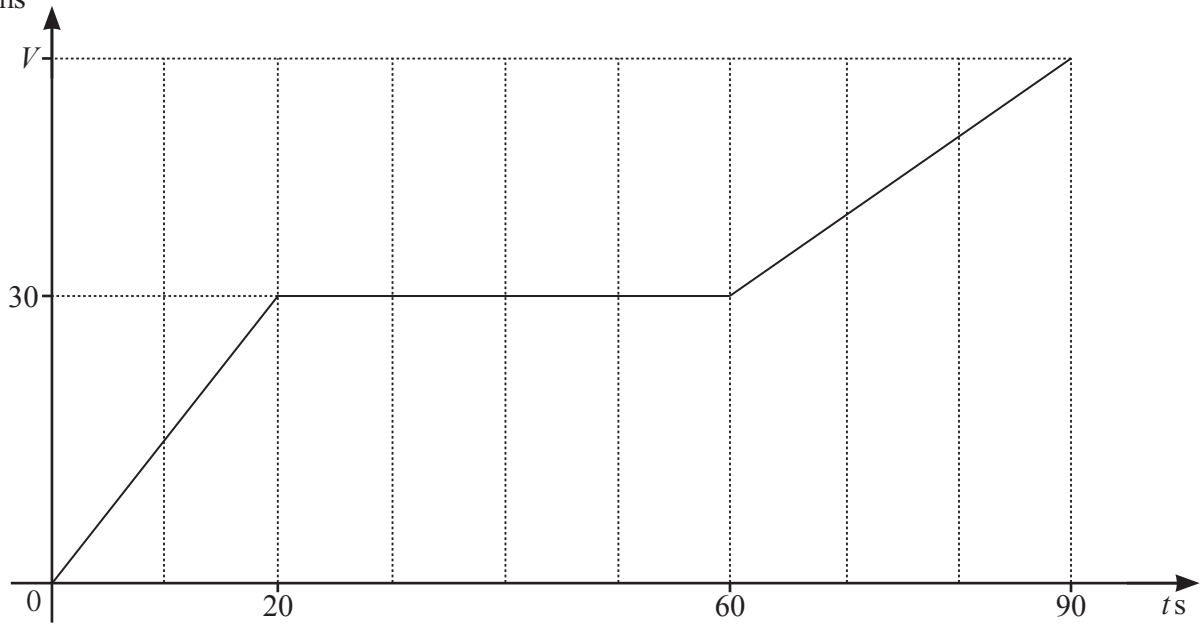
 $v \text{ ms}^{-1}$

The diagram shows the velocity–time graph of a particle P that travels 2775 m in 90 s, reaching a final velocity of $V \text{ ms}^{-1}$.

(i) Find the value of V .

[3]

(ii) Write down the acceleration of P when $t = 40$.

[1]

(b) The acceleration, $a \text{ ms}^{-2}$, of a particle Q travelling in a straight line, is given by $a = 6 \cos 2t$ at time t s. When $t = 0$ the particle is at point O and is travelling with a velocity of 10 ms^{-1} .

(i) Find the velocity of Q at time t . [3]

(ii) Find the displacement of Q from O at time t . [3]