



# Science

Stage 8

Paper 1

**2024**

## Cambridge Lower Secondary Progression Test

Name

Class

Date

**45 minutes**

No additional materials are needed.

### INSTRUCTIONS

- Answer **all** questions.
- Write your answer to each question in the space provided.
- You should show all your working on the question paper.

### INFORMATION

- The total mark for this paper is 50.
- The number of marks for each question or part question is shown in brackets [ ].

1 Pierre uses a microscope to look at some blood.



He draws an image of what he observes.

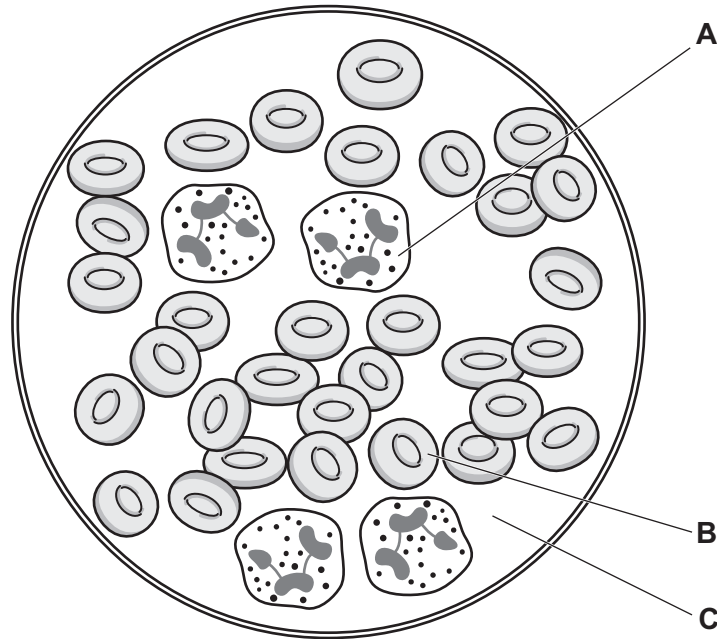

(a) Complete the table about the functions of the components of the blood.

function	letter
transports nutrients	
transports oxygen	
protects against pathogens	

[2]

(b) Pierre says,

**'I predict that animals with a larger mass will have red blood cells with a larger diameter.'**

He decides to look for secondary information from the internet.

(i) Give **one advantage** and **one disadvantage** of using secondary information from the internet.

advantage .....

.....

disadvantage .....

.....

[2]

(ii) Here is the information Pierre finds.

animal	average mass of an adult in kg	average diameter of red blood cells in $\mu\text{m}$
dog	25	7.0
horse	300	5.7
sheep	80	4.5
goat	90	3.2
human	65	7.1
cat	4.5	5.8
rabbit	1.5	6.1

Tick (✓) to show if this information supports Pierre's prediction.

yes  no

Explain your answer.

Use information from the table.

.....  
 .....  
 .....

[1]

(c) Complete the sentence.

Choose from the list.

- breathing      diffusion      digestion      respiration**

Gases move between blood and the air in the lungs by ..... [1]

2 Carlos investigates the colours in ink.



(a) The diagram shows his equipment at the start of the investigation.

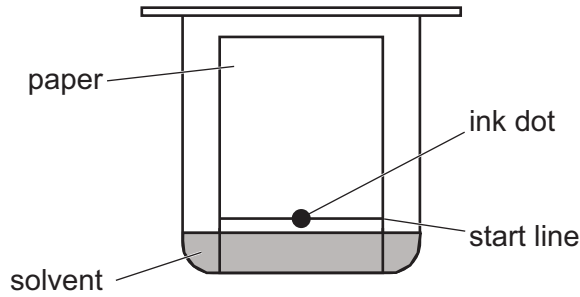

(i) Name this method of separating the colours in ink.

..... [1]

(ii) Explain why the ink dot must be above the solvent.

.....  
 .....  
 ..... [2]

(b) Carlos separates the colours from five different samples of ink.

Look at the diagram that shows the results of these separations.

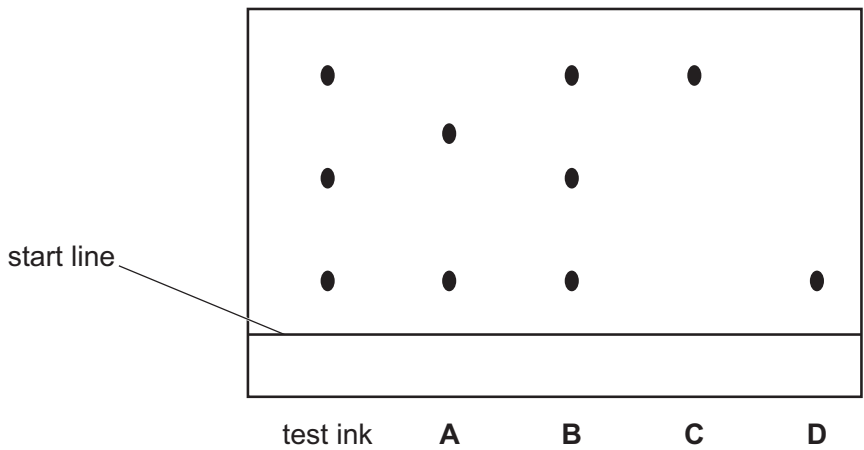

Which ink contains the same colours as the test ink?

Choose from **A, B, C** or **D** .....

Explain your answer.

.....  
 ..... [2]

3 Aiko uses a tray and some marbles to model gas pressure **in a container**.

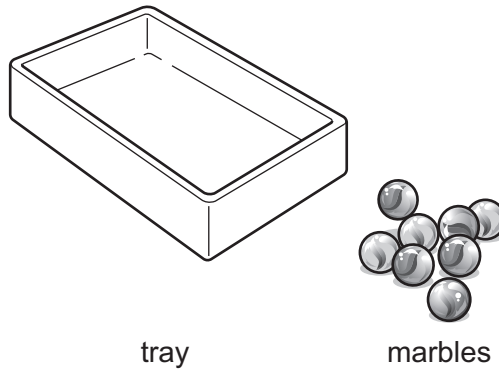

Explain how Aiko uses the equipment to model gas pressure **in a container**.

.....

.....

..... [2]

4 The diagram shows a water heating system that uses energy from the Sun.

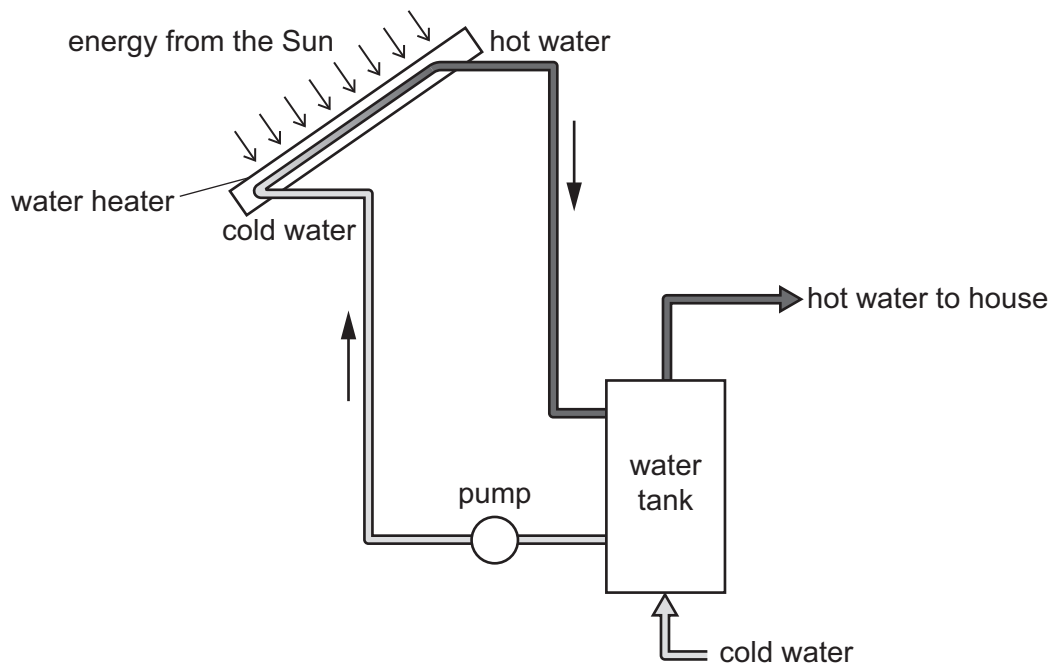

(a) (i) Write down **one** reason why this is an example of using a renewable energy resource.

.....  
..... [1]

(ii) Suggest **one disadvantage** of using this method to heat water.

.....  
..... [1]

(iii) Write down **one other renewable** energy resource.

..... [1]

(iv) Write down **one non-renewable** energy resource.

..... [1]

(b) The picture shows a container made from plant material.



Which word describes this type of renewable material?

Circle the correct answer.

**biochemical**

**bioplastic**

**cytoplasm**

**mineral**

[1]

5 A balanced diet contains many different nutrients.



Draw a straight line from each **nutrient** to its correct **function in the body**.

nutrient	function in the body
calcium	for healthy eyesight
carbohydrate	to prevent dehydration
vitamin A	to make strong bones and teeth
protein	to provide energy and to be used as an energy store
water	for tissue growth and repair

[3]

6 Lily draws a diagram to show the model of an atom.

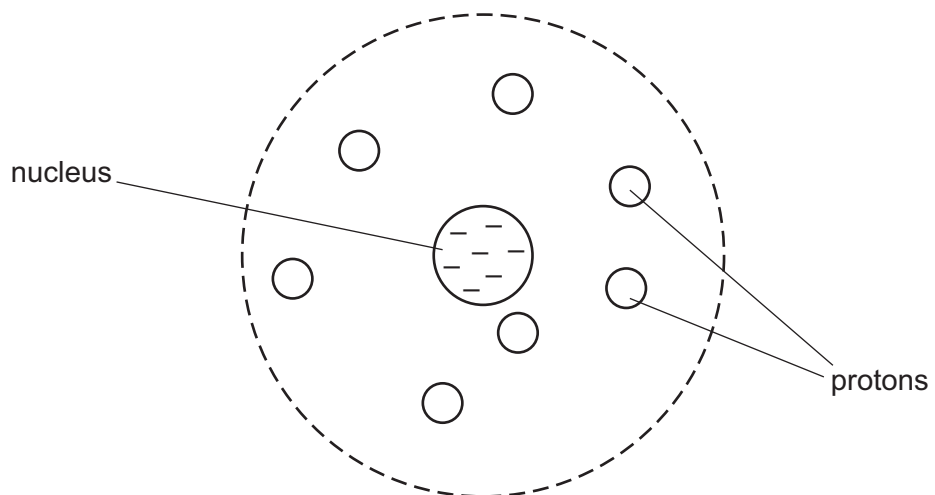

(a) (i) The diagram is **not** correct.

Write down **two** ways the diagram is **not** correct.

- 1 .....
- 2 .....
- [2]

(ii) This model is named after a scientist.

Write down the name of this scientist.

..... [1]

(b) Explain how the particles in an atom are held together.

.....

.....

..... [2]

7 This question is about asteroids.



(a) The table shows some information about asteroids that have passed near to the Earth.

asteroid	date asteroid was nearest to the Earth	nearest distance from the Earth in km
A	February 2004	5481
B	March 2004	6542
C	October 2009	6259
D	October 2019	6242
E	August 2020	2946

(i) Which asteroid passed **nearer** than 5000 km from the Earth?

..... [1]

(ii) Suggest why the distances in the table may **not** be accurate.

.....  
..... [1]

(iii) Describe how asteroids in space are formed.

.....  
..... [1]

(b) The Moon has many craters formed when asteroids hit the surface of the Moon.

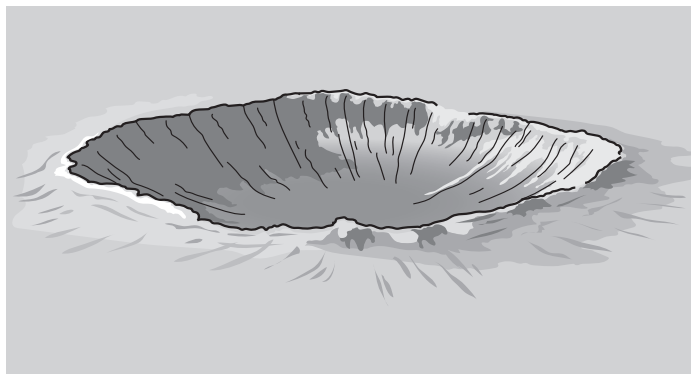

Ahmed makes this hypothesis about craters.

**'The bigger the asteroid hitting the Moon,  
the bigger the crater that is made.'**

Ahmed wants to test this hypothesis.

The diagram shows some of the equipment he uses.

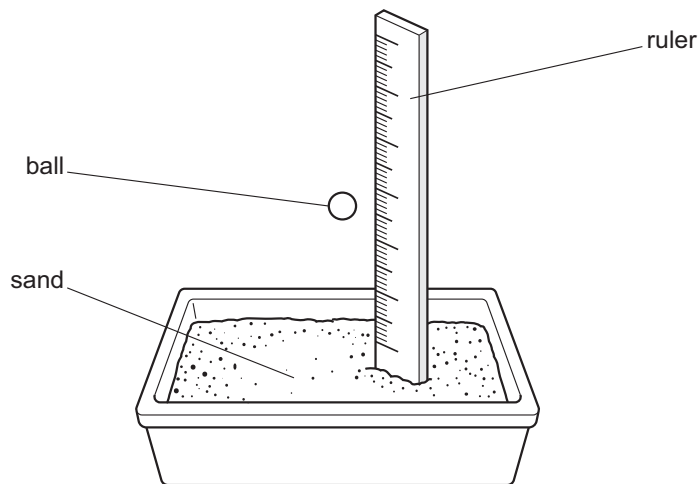

Ahmed drops the ball and measures the size of the crater.

Describe how Ahmed uses this equipment to test his hypothesis.

.....  
.....  
..... [2]

8 Safia makes an electromagnet.



Describe how Safia makes an electromagnet.

You may want to draw a diagram to help you answer the question.

.....  
.....  
..... [2]

9 Complete the crossword about aerobic respiration.

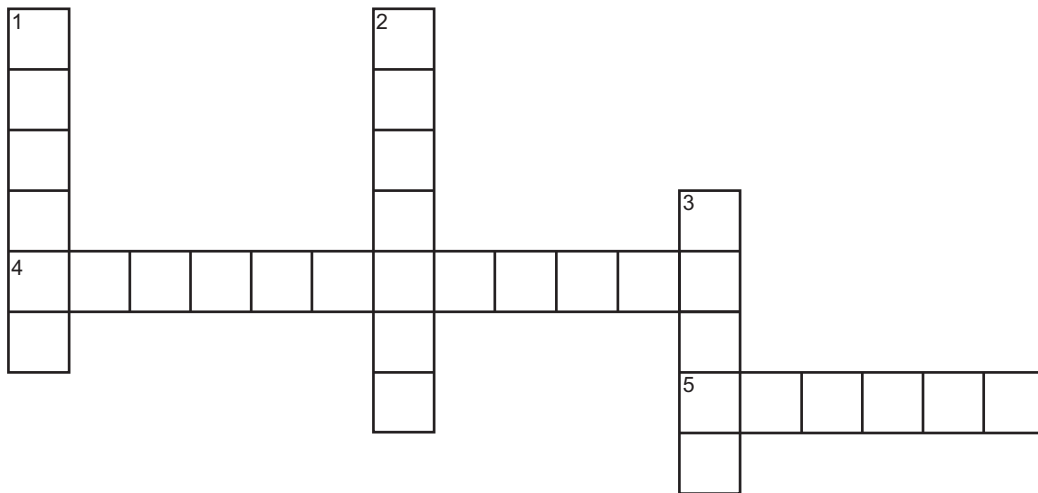

### Clues

#### 1 down

Which component of blood transports carbon dioxide?

.....

#### 2 down

Which compound is a reactant of aerobic respiration?

.....

#### 3 down

Which compound is a waste product of aerobic respiration?

.....

#### 4 across

What is the name of the structure in a cell where aerobic respiration takes place?

.....

#### 5 across

What is released during aerobic respiration?

.....

[4]

10 Blessy places two magnets next to each other as shown in the diagram.

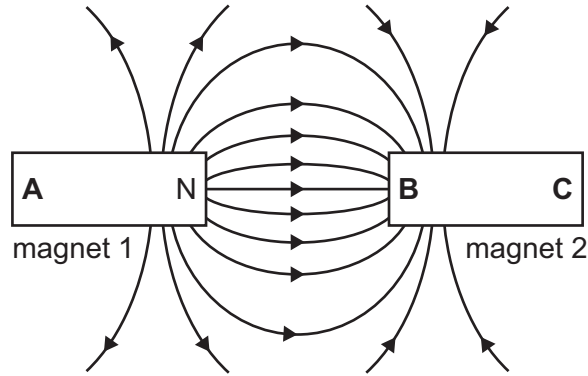

The north pole, N, is labelled on magnet 1.

The other poles are labelled **A**, **B** and **C**.

(a) (i) What is shown by the pattern of lines around the two magnets?

..... [1]

(ii) Blessy writes some statements about the two magnets.

Tick (✓) the **correct** statements.

statement	
<b>A</b> is a N pole	
<b>B</b> is a S pole	
<b>C</b> is a N pole	

[1]

(b) Blessy brings pole **D** and pole **E** of two other magnets close to each other.

The magnets push each other away.

Which sentences are possible explanations?

Tick (✓) **two** boxes.

Pole **D** and pole **E** are both S poles.

Pole **D** is a N pole and pole **E** is a S pole.

Pole **D** is a S pole and pole **E** is a N pole.

Pole **D** and pole **E** are both N poles.

[2]

11 Mike investigates the reflection of a light ray at a plane mirror.



Look at his ray diagram.

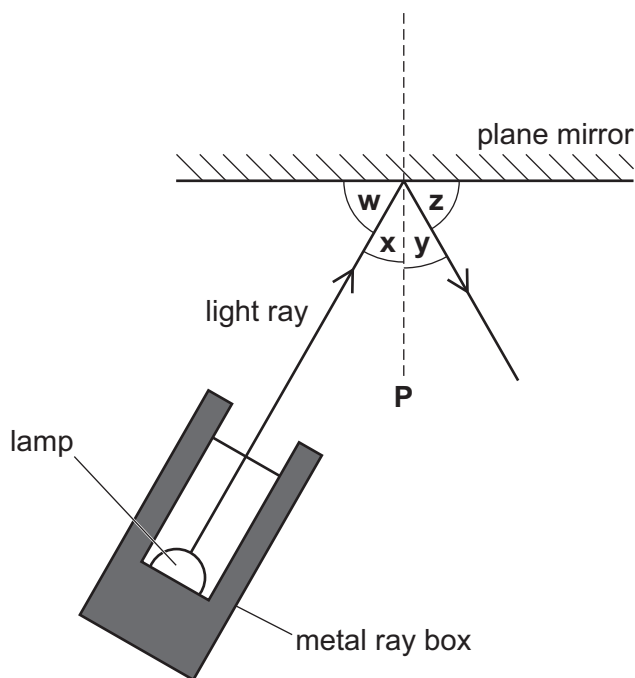

(a) (i) Write down the name of the dotted line **P** in the diagram.

..... [1]

(ii) Which row in the table identifies the angle of incidence and the angle of reflection in Mike's diagram?

	angle of incidence	angle of reflection
<b>A</b>	w	x
<b>B</b>	w	y
<b>C</b>	x	y
<b>D</b>	x	z

row .....

[1]

(b) Mike changes the angle of incidence and measures the angle of reflection.

The table shows the angles of incidence he uses.

Complete the table to predict the angles of reflection.

angle of incidence in °	angle of reflection in °
20	.....
30	.....
40	.....
50	.....

[1]

(c) Mike uses a metal ray box connected to a power supply in his investigation.

Write down **one** safety hazard in Mike’s investigation.

Describe how he avoids this hazard.

safety hazard .....

description of how Mike avoids the hazard .....

.....

[2]

12 Mia investigates solubility.



In her first experiment Mia:

- step 1 - pours 50 cm<sup>3</sup> of water into a beaker
- step 2 - records the temperature of the water
- step 3 - adds 1g of a salt to the water
- step 4 - stirs the water until the salt dissolves
- step 5 - repeats steps 3 and 4 until no more salt dissolves
- step 6 - records the total mass of salt that dissolves.

Mia repeats the experiment four more times.

Each time she uses a different temperature of water.

Look at her results.

temperature of water in °C	mass of salt that dissolves in g
20	12
30	22
40	24
50	42
60	50

(a) What is the independent variable in this investigation?

..... [1]

(b) Describe the relationship between the temperature of the water and the mass of salt that dissolves.

.....  
 ..... [1]

(c) Mia says,

**‘I do not think my results are reliable.’**

Write down **two** reasons why Mia is correct.

1 .....  
 .....  
 2 .....  
 .....

[2]