



Science

Stage 7

Paper 2

2022

Cambridge Lower Secondary Progression Test

Name

Class

Date

45 minutes

No additional materials are needed.

INSTRUCTIONS

- Answer **all** questions.
- Write your answer to each question in the space provided.
- You should show all your working on the question paper.

INFORMATION

- The total mark for this paper is 50.
- The number of marks for each question or part question is shown in brackets [].

1 Look at the diagrams of different cells.

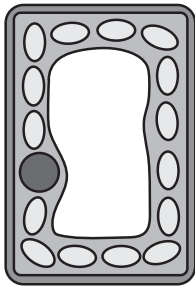

A

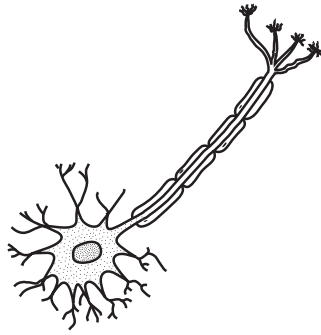

B

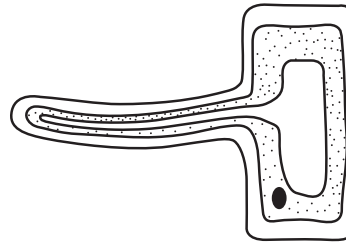

C

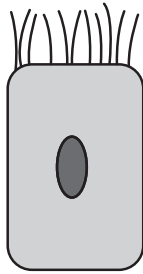

D

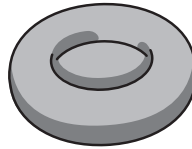

E

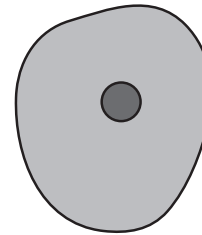

F

NOT TO SCALE

(a) Four of the cells are animal cells.

Write down the letters of the **four animal** cells.

..... [1]

(b) Write down **two** reasons why these cells are animal cells and **not** plant cells.

1

2

[2]

(c) Microorganisms are made of cells.

How many cells does a typical microorganism contain?

..... [1]

2 Steel is an alloy.



It contains carbon and iron.

(a) Complete the sentence by ticking (✓) the correct box.

Steel is

an atom

an element

a compound

a mixture

[1]

(b) Look at the particle models for steel and iron.

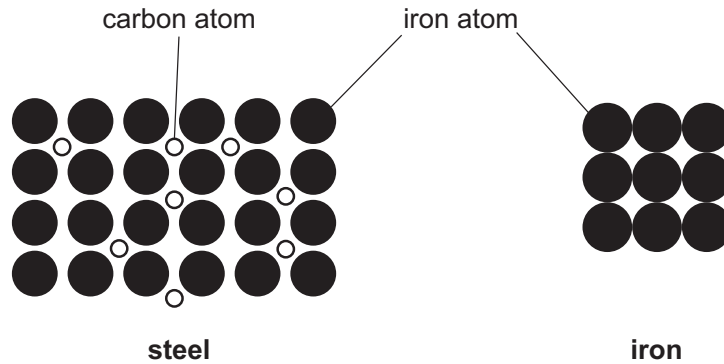

Explain, using the particle model, why steel is harder than iron.

.....

.....

..... [2]

3 Pierre and Priya investigate air resistance.



They have a ball and a feather.

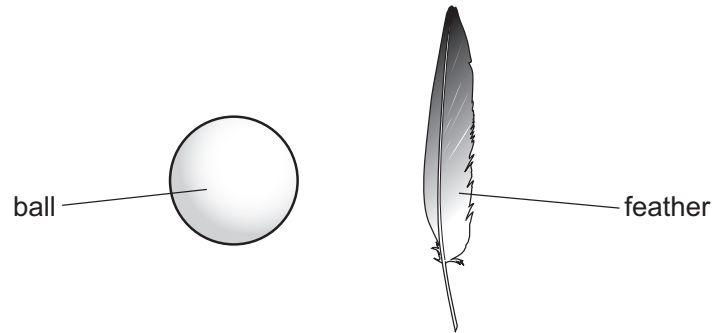

Pierre drops the ball and the feather from the same height.

Priya times how long it takes for the ball and the feather to reach the ground.

They repeat their experiment three times.

Here are their results.

object	time taken to reach the ground in seconds			average time taken to reach the ground in seconds
	experiment 1	experiment 2	experiment 3	
ball	2.6	2.4	2.5	2.5
feather	25	23	24	24

(a) Explain their results.

Use ideas about air resistance.

.....

.....

.....

.....

[2]

(b) Pierre makes this prediction,

'If we repeat the investigation in a vacuum the ball and the feather will both take the same time to reach the ground.'

Tick (✓) to show if Pierre is correct.

Yes

No

Explain your answer.

.....

.....

[1]

4 Look at the diagram.



It shows the position of the Sun, the Earth and the tides.

(a) Complete the diagram by showing the position of the Moon.

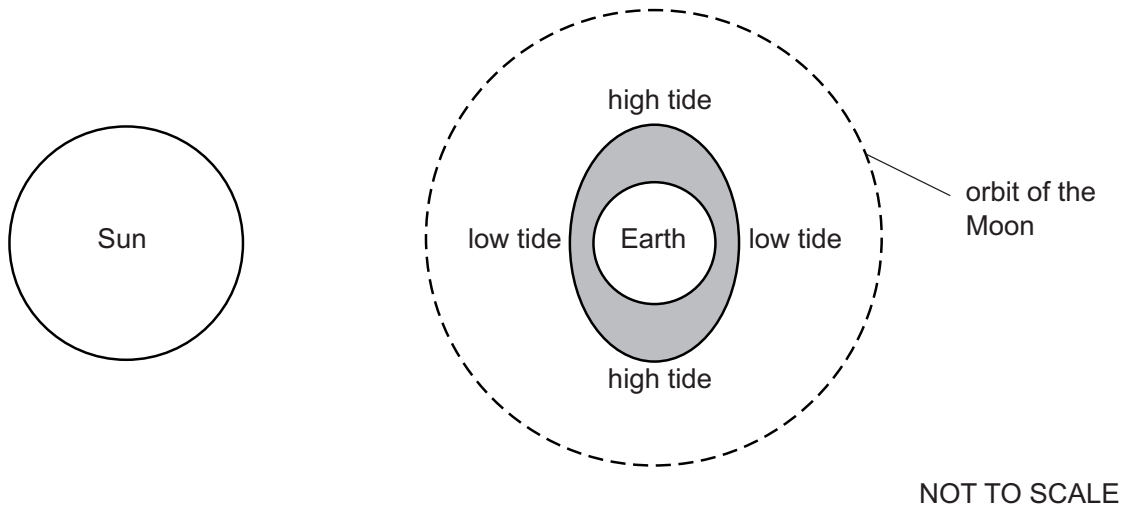

[1]

(b) Look at the diagram.

It shows the Earth with extremely high tides.

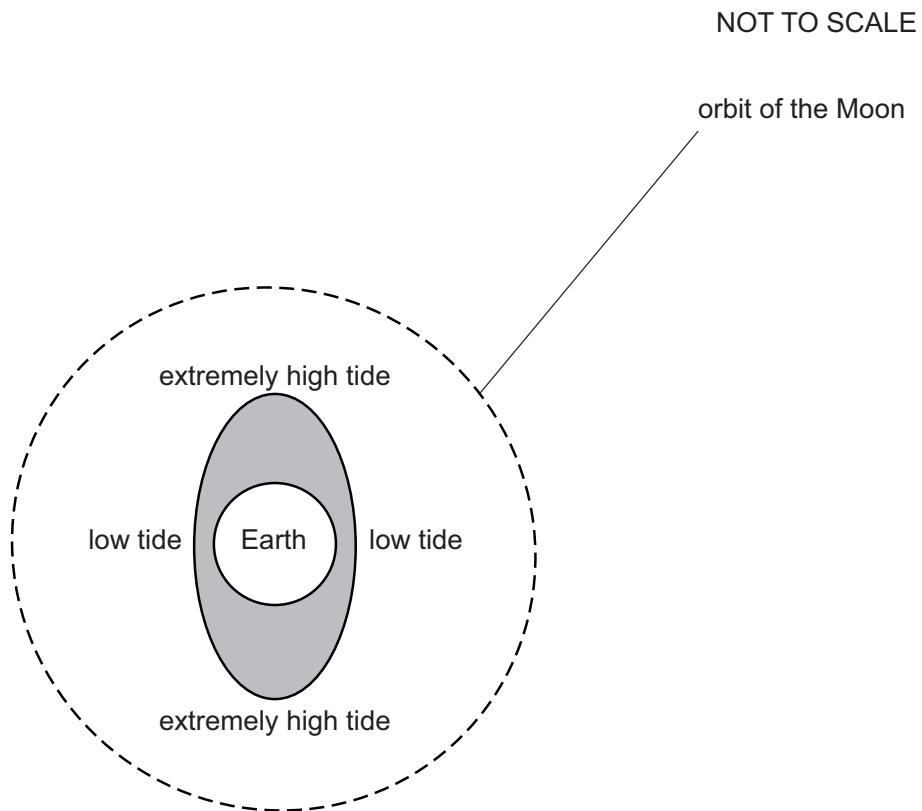

Complete the diagram to show the position of the Sun **and** the position of the Moon when there is an extremely high tide.

Explain your answer.

.....

.....

[2]

5 Chen uses his toy train to model the flow of electricity in an electrical circuit.



Chen pushes the train around the track.

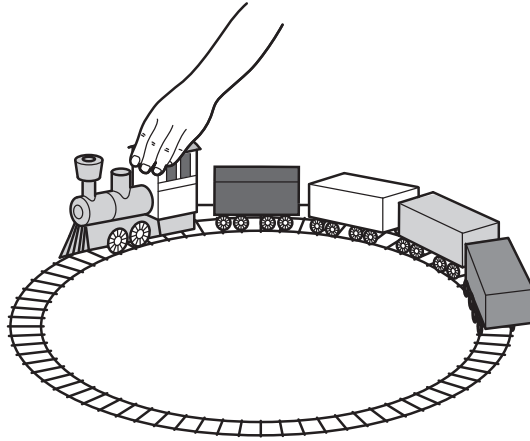

(a) Draw a line to match the **part of the model** to the correct part of the **electrical circuit**.

part of the model

electrical circuit

train

wire

track

battery

Chen

electrons

[1]

(b) (i) Write down **one strength** of Chen's model.

..... [1]

(ii) Write down **two limitations** of Chen's model.

1

2

[2]

6 Oliver investigates the current in an electrical circuit.

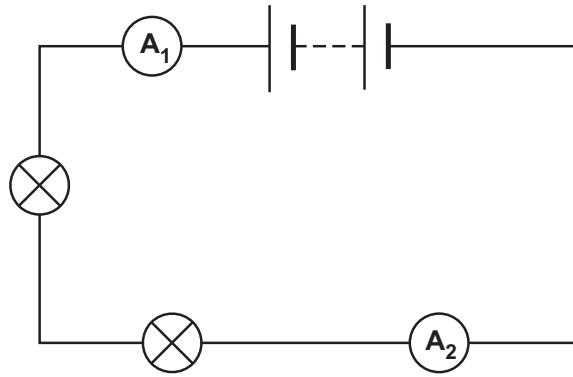

Ammeter **A₁** measures the current as 4 amps.

(a) Write down the measurement on ammeter **A₂**.

..... amps [1]

(b) Oliver adds another lamp to the electrical circuit.

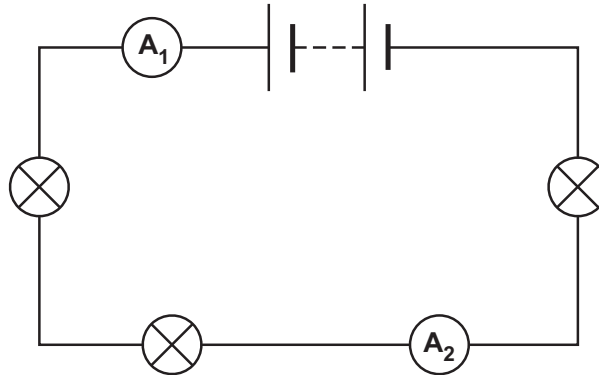

Describes what happens to the measurement on ammeter **A₁**.

Explain your answer.

measurement on **A₁**

explanation

.....

[1]

7 Look at the three food chains for a desert.



cactus → rat → hawk → microorganisms

cactus → grasshopper → lizard → hawk → microorganisms

cactus → rat → tarantula → snake → microorganisms

(a) Use the food chains to make a food web.

[3]

(b) There is a disease which kills **all** the grasshoppers in the desert.

Predict what happens to the number of lizards in the desert.

.....

Explain your answer.

.....

.....

[1]

(c) (i) What is the role of the microorganisms in a food web?

..... [1]

(ii) Explain why microorganisms are important in a habitat.

.....
..... [1]

8 Jamila mixes two colourless solutions.



(a) (i) Complete these sentences.

The two solutions react to make a white solid.

The solid made does **not** dissolve in water because it is

This solid is called a [2]

(ii) A reaction takes place when Jamila mixes the two solutions.

Describe **one** piece of evidence that shows a reaction takes place.

..... [1]

(b) What is the name of this type of chemical reaction?

..... [1]

9 Blessy slowly adds sodium hydroxide solution to dilute hydrochloric acid in a beaker.



As she adds the sodium hydroxide solution to the acid, Blessy measures the pH of the mixture in the beaker.

Look at the graph of her results.

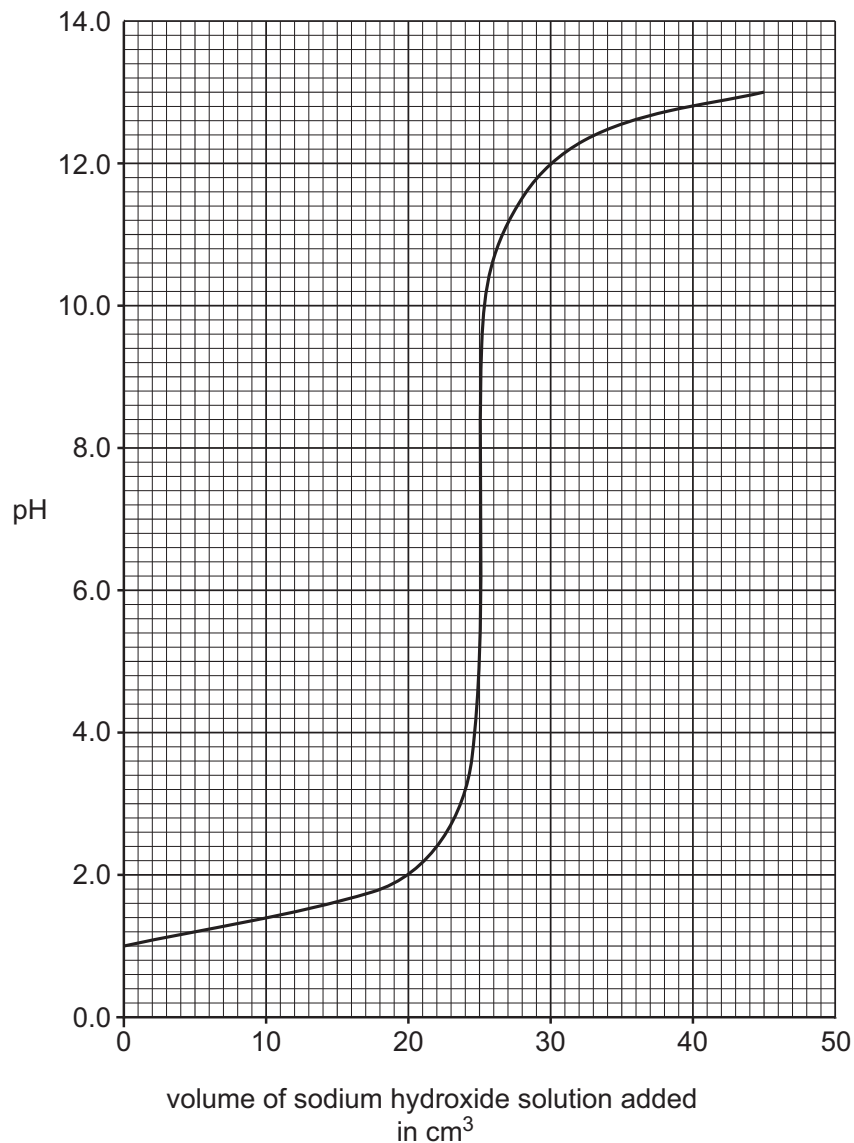

(a) Sodium hydroxide solution is an alkali.

Write down the name of the type of reaction that happens when sodium hydroxide solution reacts with dilute hydrochloric acid.

..... [1]

(b) Explain why the pH increases as the sodium hydroxide solution is added to the dilute hydrochloric acid.

.....
..... [1]

(c) What is the volume of sodium hydroxide solution added when the pH is 7.0?

..... cm³ [1]

(d) Blessy wants to know if her results are reliable.

Describe what Blessy does to get reliable results.

Explain how she will know if the results are reliable.

description

explanation

[2]

10 The mountain zebra belongs to the species, *Equus zebra*.

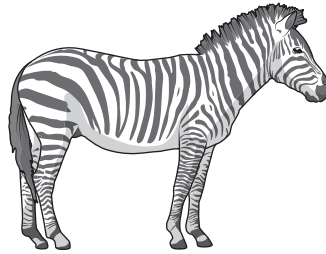

(a) Define the term **species**.

.....
.....
..... [2]

(b) Growth is one characteristic of living organisms.

Write down **three other** characteristics of the living organisms shown in the pictures.

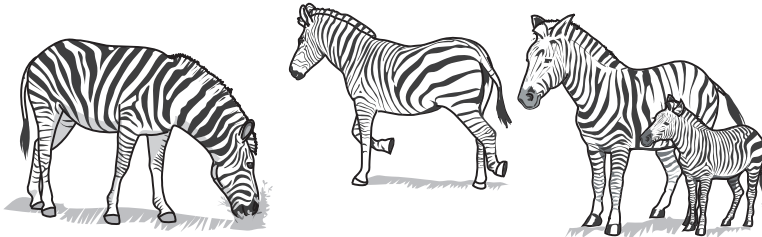

1
2
3

[2]

(c) A virus makes the mountain zebra become ill.

Mia thinks a virus is a living organism.

Tick (✓) to show if Mia is correct.

Yes No

Explain your answer.

.....
.....

[1]

11 The combustion of gasoline in a car engine makes harmful gases.



Catalytic converters are fitted to cars to lower the mass of these harmful gases released into the atmosphere.

Look at the graph.

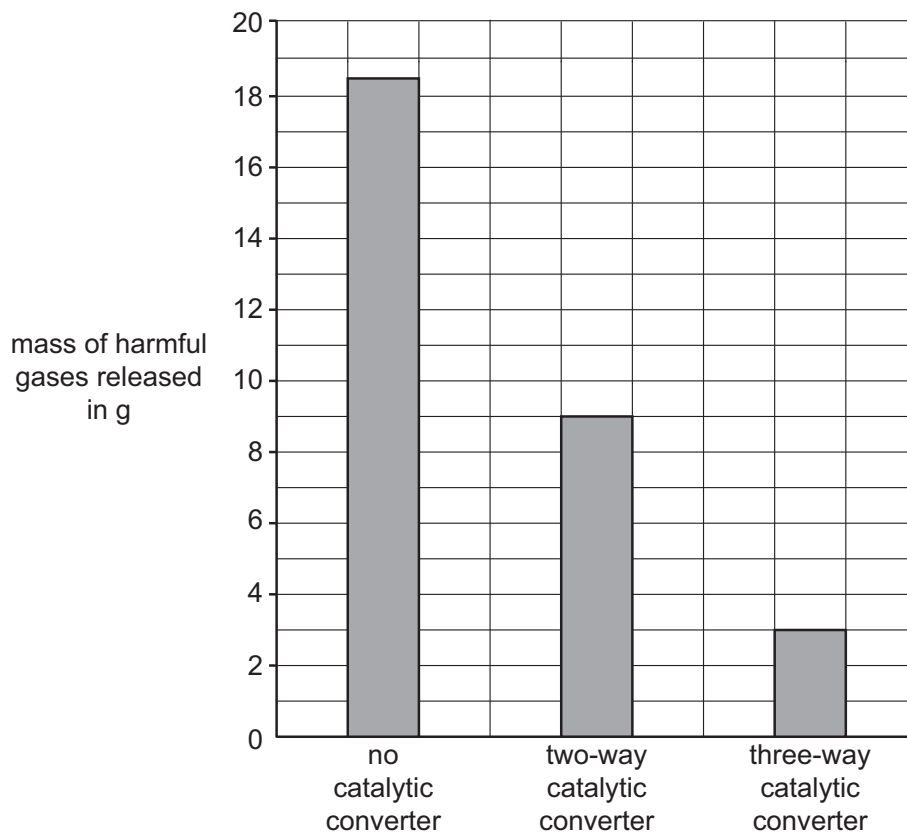

A three-way catalytic converter is more effective than a two-way catalytic converter at lowering the mass of harmful gases released.

Calculate how much more effective the three-way catalytic converter is compared to the two-way catalytic converter.

Show your working.

..... [2]

12 Hassan stands in the entrance of a tunnel and shouts his name into the tunnel.

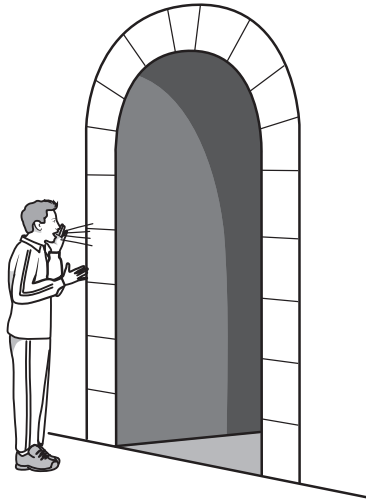

A few seconds later he hears his name again.

Explain why.

.....

.....

..... [2]

13 Safia and Pierre use boxes and pieces of cloth to model how fold mountains are formed.



Look at the diagram.

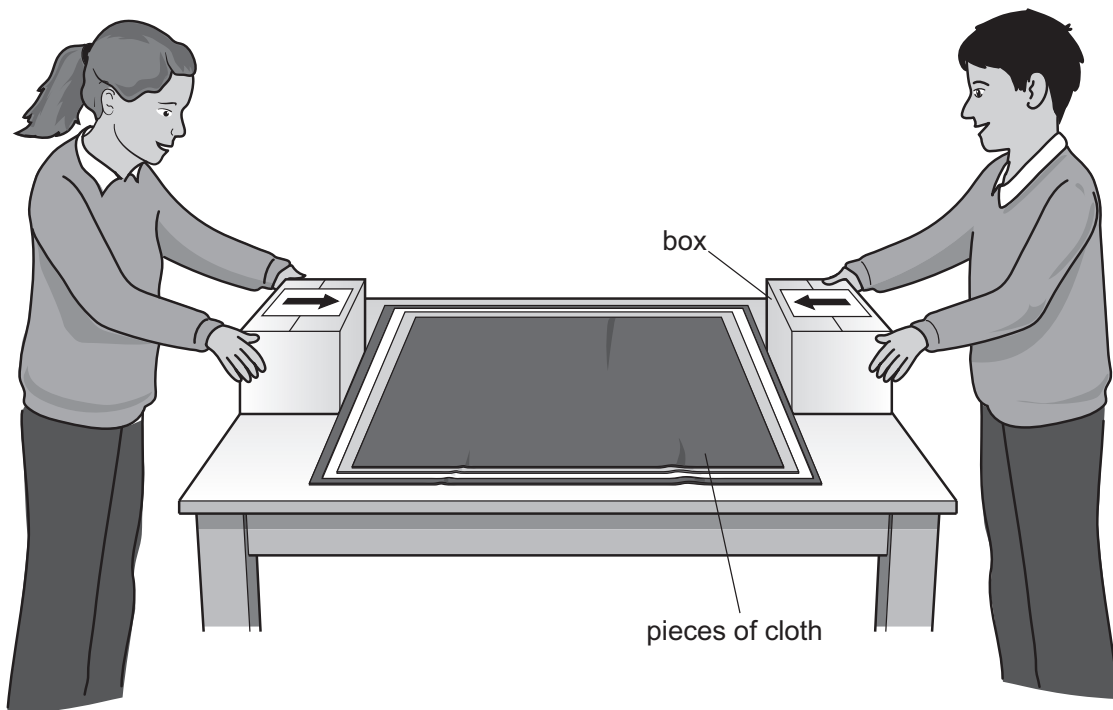

(a) Safia and Pierre push the boxes towards each other.

Use your scientific knowledge to predict what happens to the pieces of cloth.

..... [1]

(b) (i) What do the boxes in the model represent?

..... [1]

(ii) What do the pieces of cloth in the model represent?

..... [1]

(c) Suggest **one** way Safia and Pierre could improve their model.

..... [1]

14 Read the hypothesis about how planets are formed.



About 4500 million years ago the Solar System was just gas and dust.

Small bits of gas and dust began to group together to form asteroids.

Gravity pulled some of the asteroids together to form planets.

Many asteroids are still found between Mars and Jupiter.

(a) Write down **one** reason why some scientists think this hypothesis may **not** be correct.

.....
..... [1]

(b) Write down **two** reasons why some scientists think this hypothesis is correct.

1
.....

2
.....

[2]