



# Science

Stage 7

Paper 1

**2026**

## Cambridge Lower Secondary Progression Test

Name

Class

Date

**45 minutes**

No additional materials are needed.

### INSTRUCTIONS

- Answer **all** questions.
- Write your answers to each question in the space provided.
- You should show all your working on the question paper.

### INFORMATION

- The total mark for this paper is 50.
- The number of marks for each question or part question is shown in brackets [ ].

1 Pierre uses the internet to research about viruses.



Three websites say that viruses are living organisms.

Six websites say that viruses are non-living.

(a) Explain why it is important for Pierre to know the source of each website.

.....

.....

.....

..... [2]

(b) Pierre says,

**‘Some people classify viruses as alive because they show one of the seven characteristics of living organisms.’**

Write down this characteristic of living organisms.

..... [1]

2 Elements are organised in the Periodic Table.



The diagram shows part of the Periodic Table.

Group											
1	2					3	4	5	6	7	8
				H							
							C				Ne
Na						Al				Cl	

Write down **one** symbol for a metal and **one** symbol for a non-metal.

Choose symbols from the diagram.

metal .....

non-metal .....

[2]

3 This question is about energy changes.



Look at the diagram showing Mike climbing a slide.



(a) There is an energy change when Mike climbs the stairs and travels down the slide.

Complete the sentences to describe the **main** energy changes.

As Mike climbs the stairs, ..... energy increases.

As Mike travels down the slide, ..... energy increases.

[2]

(b) Some energy is dissipated as Mike moves down the slide.

What does the term **dissipated** mean?

.....  
..... [1]

4 Look at the diagram showing part of the water cycle.



(a) Write down the names of processes A, B, C and D.

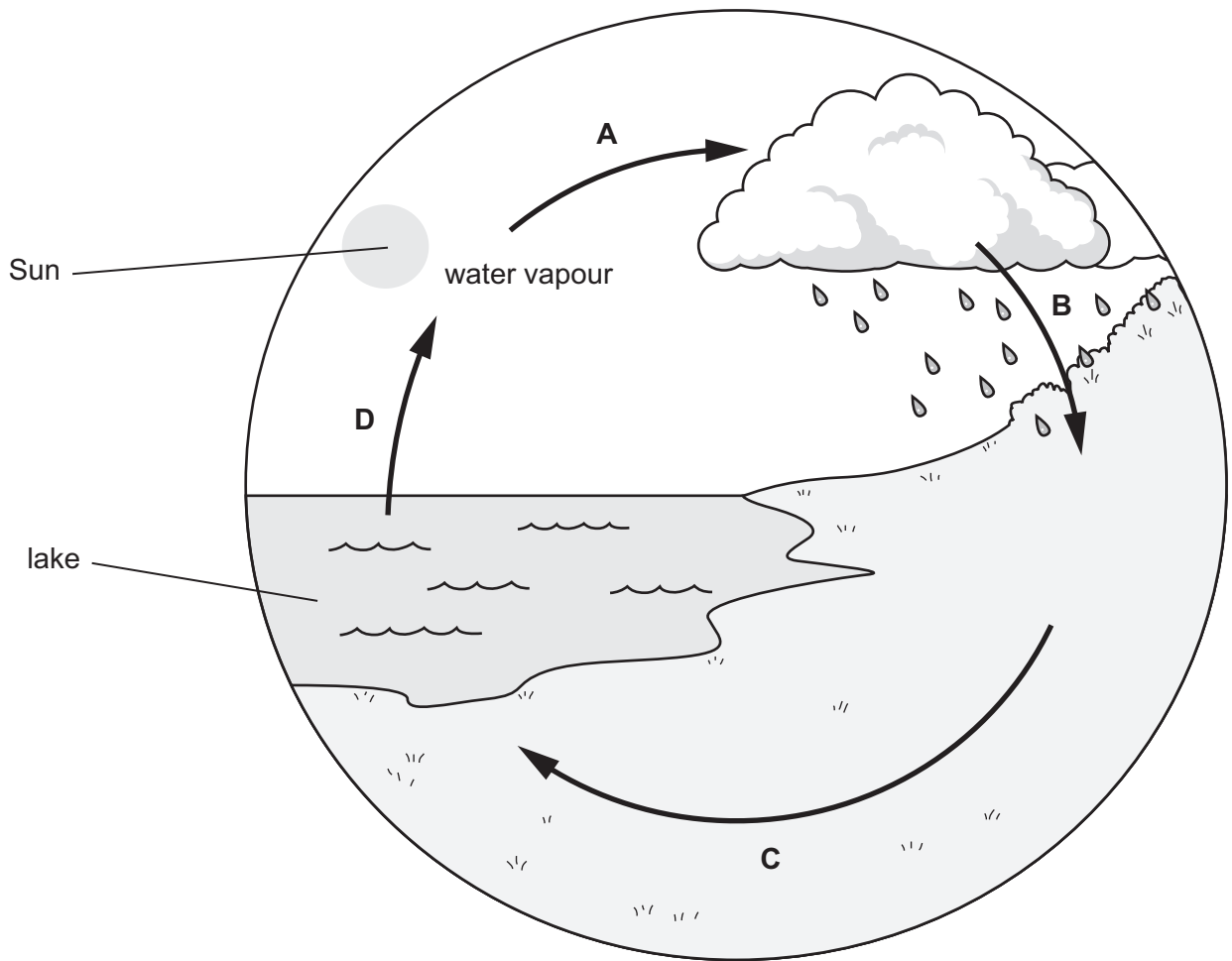

- A .....
- B .....
- C .....
- D .....

[4]

(b) Lily is a scientist.

She tests some water from the lake with a chemical.

The chemical is hazardous to the environment and a health hazard.

Circle the **two** hazard symbols on the bottle of chemical.

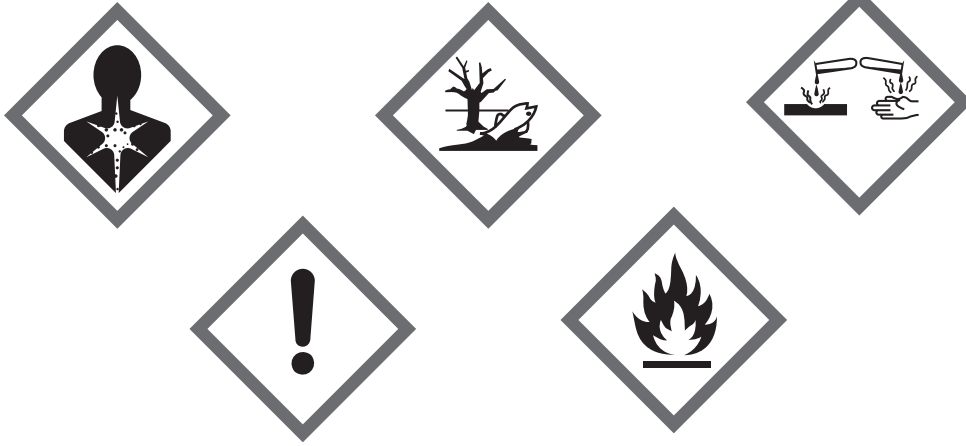

[2]

5 Look at the diagrams of five organisms.



sloth



bear



human



owl



butterfly

not to scale

Mia classifies the organisms into two groups, **A** and **B**.

group **A**:

- sloth, bear, human

group **B**:

- owl, butterfly

(a) Write down **one** characteristic used to sort the organisms into group **A** and group **B**.

Explain your answer.

characteristic .....

explanation .....

[1]

(b) Mia uses the diagrams to write this conclusion about the group **A** organisms.

**‘All group A organisms have teeth.’**

There is **not** enough evidence to support this conclusion.

Write down **one** reason why.

.....  
..... [1]

- 6 Oliver adds three drops of Universal Indicator solution to a sample of dilute hydrochloric acid.



(a) What is the colour of the Universal Indicator in the acid?

..... [1]

(b) Oliver then adds some sodium hydrogencarbonate to the acid.

The mixture fizzes and the Universal Indicator changes to a blue colour.

(i) Write down **two** reasons why adding sodium hydrogencarbonate to dilute hydrochloric acid is a chemical reaction.

1 .....

2 .....

[2]

(ii) Write down the name of the type of chemical reaction that takes place.

..... [1]

- 7 Jamila uses a model to represent the particles in a mixture of liquids.



Look at the model.

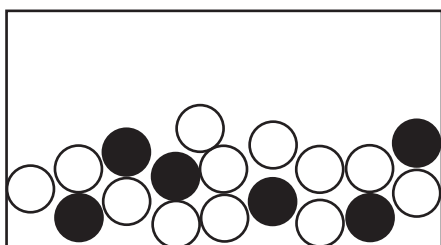

Suggest **one** strength and **one** limitation of this model.

strength .....

.....

limitation .....

.....

[2]

8 This question is about sound.



Look at the table showing the speed of sound through the three states of matter.

state of matter	approximate speed of sound in m/s
solid	5000
liquid	1500
gas	340

(a) Suggest why sound travels faster through a solid.

Use ideas about particles.

.....

.....

..... [2]

(b) Bats use echoes to hunt prey.

(i) What is an echo?

.....

..... [1]

(ii) A bat produces a sound wave.

6 seconds later the bat hears the echo from its prey.

The sound travels 340 m in 1 second.

Calculate the total distance travelled by the sound.

..... m

Calculate the distance between the bat and the prey.

..... m

[2]

9 Chen uses plastic sheets and wooden blocks to model an event at the surface of the Earth.



Look at the diagram of his model.

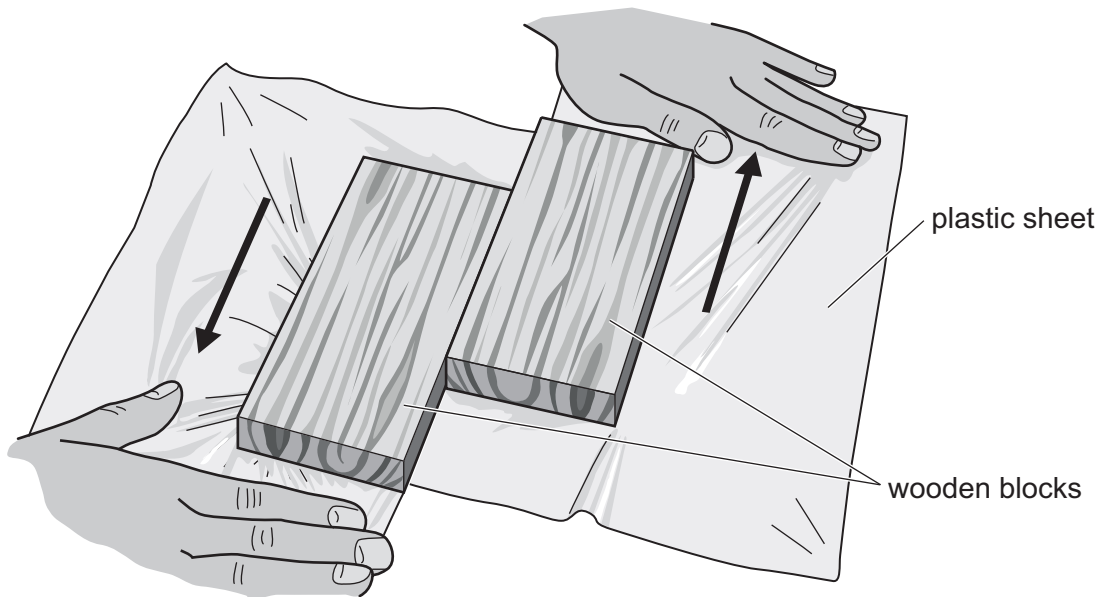

(a) The arrows show the directions that Chen pulls the plastic sheets.

What event is he modelling?

Circle the correct answer.

earthquake

mountain folding

rock formation

volcanic eruption

[1]

(b) What do the plastic sheets represent?

..... [1]

10 Safia investigates current in different series circuits.



Look at the diagram of her first circuit.

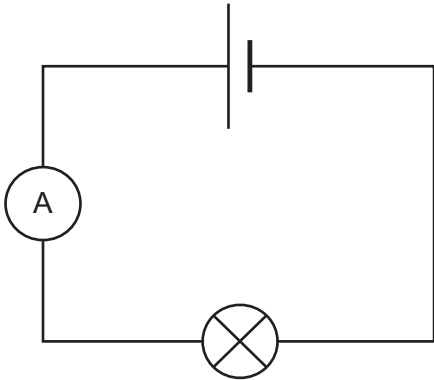

Safia:

- records the current for her first circuit
- adds another lamp in series to the circuit
- records the current for this circuit
- adds more lamps in series and records the current.

Here are her results.

1 lamp 5.0 A	2 lamps = 2.4 A
1.5 A for 3 lamps	
4 lamps = 1.2 A	5 lamps = 0.9 A

(a) Complete the table for her results.

number of lamps	current in .....

[2]

(b) Complete the sentence to describe the pattern in the results.

As the number of lamps increases, the current ..... [1]

(c) Safia thinks her results are reliable.

Tick (✓) to show if Safia is correct.

yes  no

Explain your answer

.....  
 ..... [1]

(d) Safia wants to **increase** the current for a circuit with five lamps.

Name the component she adds to the circuit.

..... [1]

11 Some cells are specialised.



(a) Draw a straight line from each **specialised cell** to its **main function**.

specialised cell	main function
ciliated cells	absorbs water and minerals
palisade cells	transports oxygen around the body
root hair cells	photosynthesis
red blood cells	moves mucus and particles out of airways

[3]

(b) Look at the diagram of a neurone.

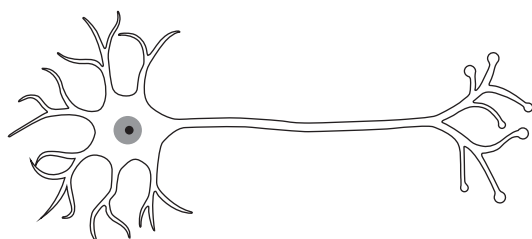

Neurones are specialised cells that transmit electrical signals in the nervous system.

Write down **one** way the structure of a neurone is related to its function.

.....  
 ..... [1]

12 Outer space is a vacuum.

**K** What is a vacuum?

..... [1]

13 This question is about food webs.

**K** (a) Look at the incomplete diagram of a food web.

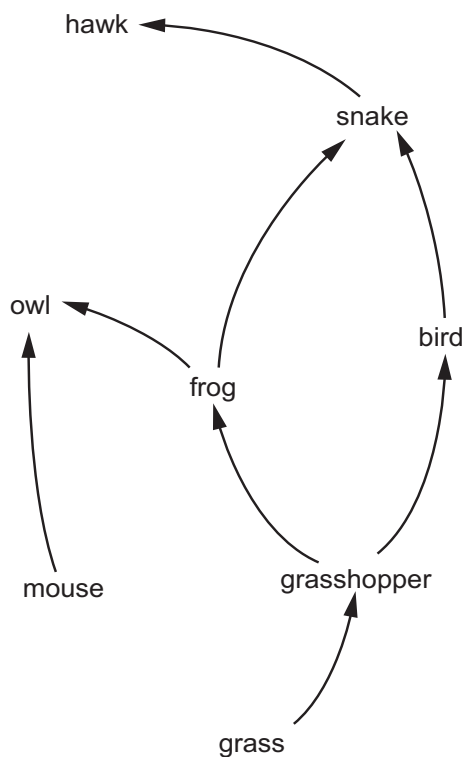

Complete the food web to show that:

- the mouse feeds on grass
- the hawk feeds on the mouse.

[2]

(b) Describe the ecological role of decomposers in a food web.

.....  
 ..... [1]

14 Steel is an alloy that contains carbon and iron.

 Steel is harder than pure iron.

Look at the particle diagrams of pure iron and of steel.

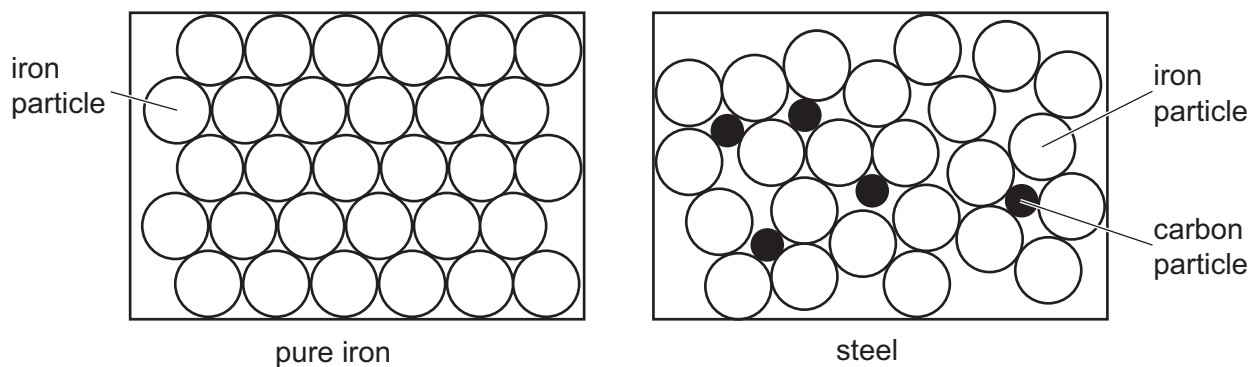

Compare the particle diagram of pure iron with the particle diagram of steel.

.....  
 .....  
 .....  
 .....  
 .....  
 ..... [3]

15 Look at the diagram showing the Sun, the Earth and the orbit of the Moon.

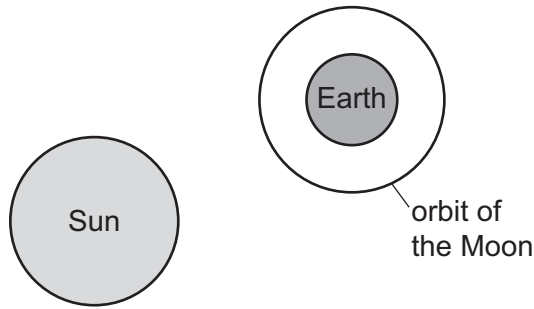

not to scale

Sometimes a lunar eclipse happens.

(a) Draw a circle on the diagram to represent the position of the Moon during a lunar eclipse. [1]

(b) Write down the name of the force which keeps the Moon in orbit around the Earth.  
..... [1]

16 Two physical properties of metals are they are hard and have high boiling points.



Write down **three other** physical properties of metals.

- 1 .....
- 2 .....
- 3 .....

[3]