

- 1 (a) Malena has 450 fruit trees.
 The fruit trees are in the ratio apple : pear : plum = 8 : 7 : 3.

October/November 2021

- (i) Show that Malena has 200 apple trees.

[2]

- (ii) Find the number of plum trees.

..... [1]

- (iii) Malena wants to increase the number of pear trees by 32%.

Calculate the number of extra pear trees she needs.

..... [2]

- (iv) Each apple tree produces 48.5 kg of apples.
 The apples have an average mass of 165 g each.

Calculate the total number of apples produced by the 200 trees.
 Give your answer correct to the nearest 1000 apples.

..... [3]

(b) Malena’s land is valued at three million and seventy-five thousand dollars.

(i) Write this number in figures.

..... [1]

(ii) Write your answer to **part (b)(i)** in standard form.

..... [1]

(c) In 2020, each plum tree produced 37.7 kg of plums.
This was 16% more than in 2019.

Calculate the mass of plums produced by each plum tree in 2019.

..... kg [2]

(d) Malena invests \$1800 at a rate of 2.1% per year compound interest.

Calculate the value of her investment at the end of 15 years.

\$ [2]

- 2 (a) The cumulative frequency diagram shows information about the floor area, $a \text{ m}^2$, of each of 80 houses.

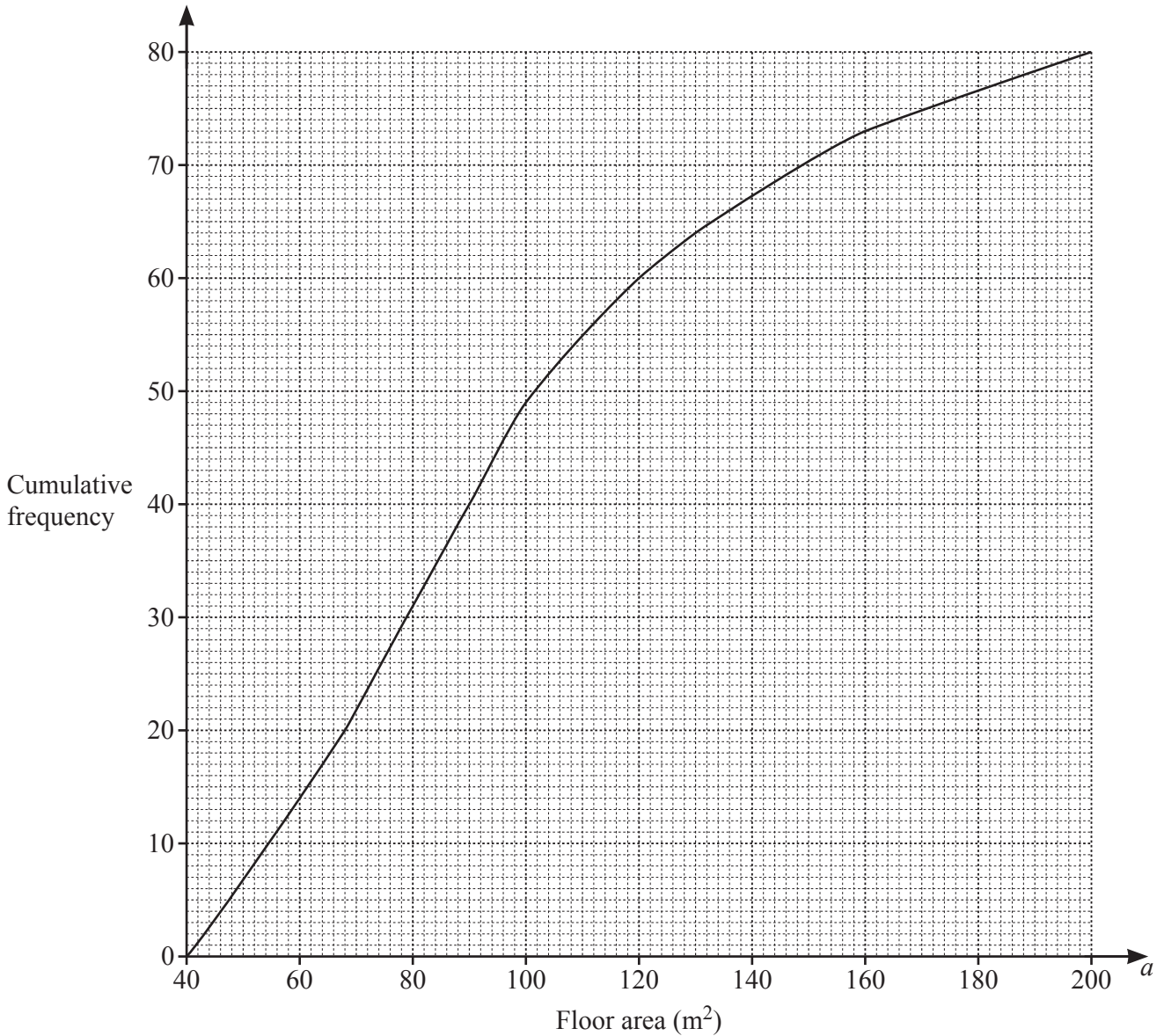

Use the diagram to find an estimate of

- (i) the median, m² [1]
- (ii) the lower quartile, m² [1]
- (iii) the interquartile range, m² [1]
- (iv) the number of houses with a floor area greater than 120 m².
..... [2]

(b) The information about the 80 floor areas is shown in this frequency table.

Floor area ($a \text{ m}^2$)	$40 < a \leq 60$	$60 < a \leq 80$	$80 < a \leq 100$	$100 < a \leq 130$	$130 < a \leq 160$	$160 < a \leq 200$
Frequency	14	17	18	15	9	7

(i) Calculate an estimate of the mean floor area.

..... m^2 [4]

(ii) Complete the histogram to show the information in the frequency table.

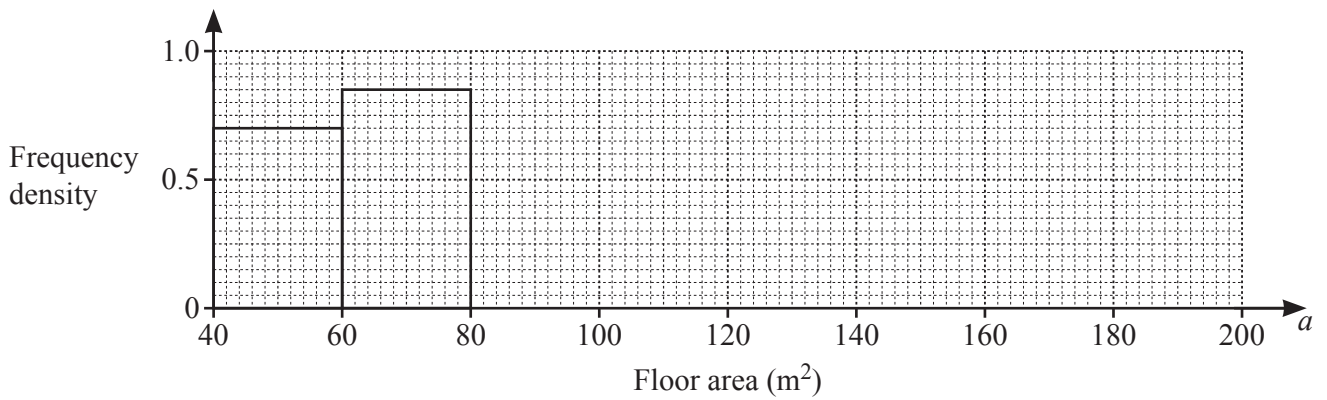

[4]

(iii) Two of the houses are picked at random.

Find the probability that one of the houses has a floor area greater than 130 m^2 and the other has a floor area 60 m^2 or less.

..... [3]

3 (a)

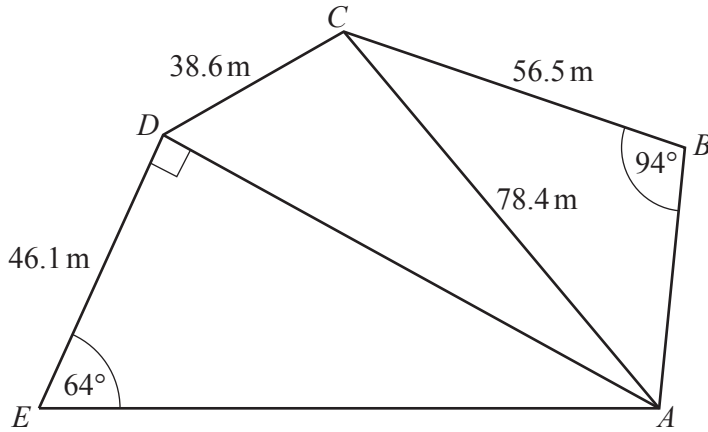
NOT TO
SCALE

$ABCDE$ is a pentagon.

- (i) Calculate AD and show that it rounds to 94.5 m, correct to 1 decimal place.

[2]

- (ii) Calculate angle BAC .

Angle $BAC = \dots\dots\dots$ [3]

- (iii) Calculate the largest angle in triangle CAD .

$\dots\dots\dots$ [4]

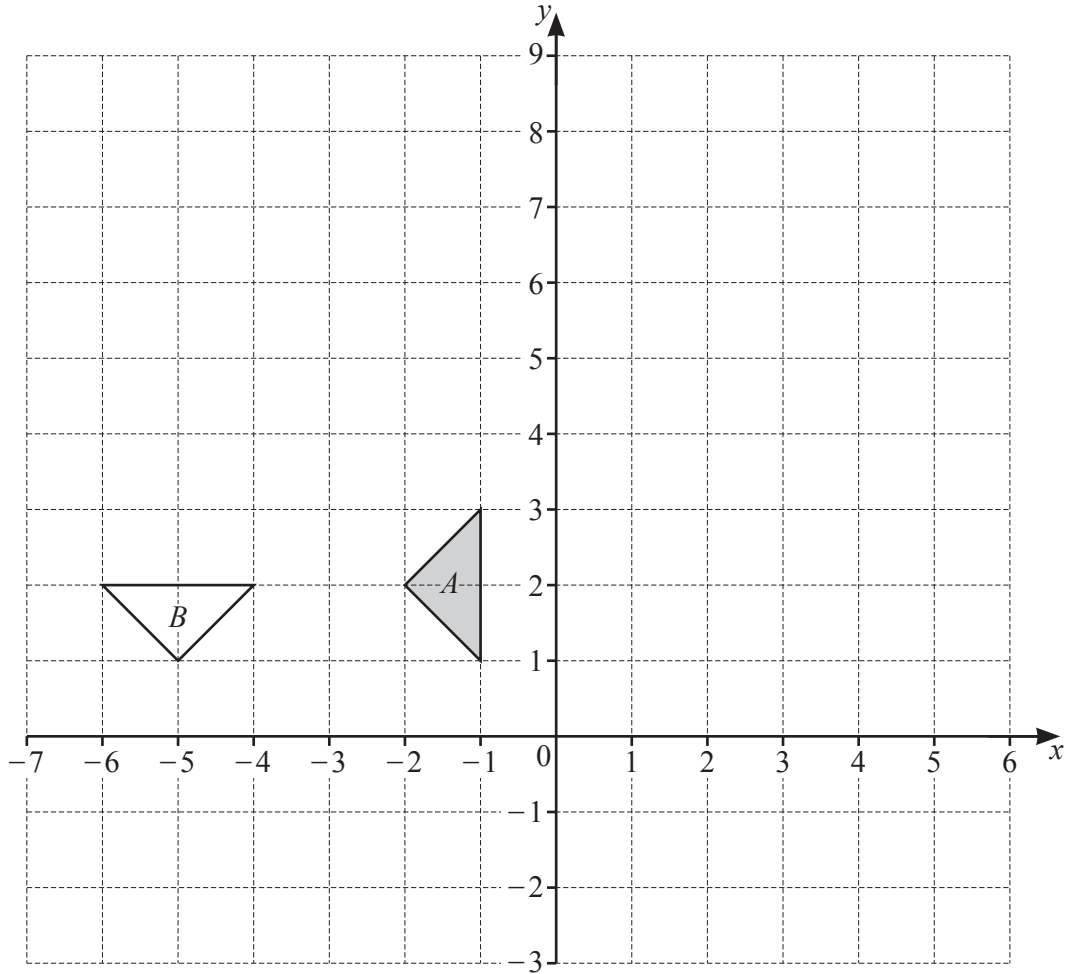

(a) On the grid, draw the image of triangle A after

(i) a translation by the vector $\begin{pmatrix} -4 \\ 5 \end{pmatrix}$, [2]

(ii) a reflection in the line $x = 1$, [2]

(iii) an enlargement, scale factor 2 and centre $(-5, -2)$. [2]

(b) Describe fully the **single** transformation that maps triangle A onto triangle B .

.....

..... [3]

5 The table shows some values for $y = x^3 - 3x^2 + 3$.



x	-1	-0.5	0	0.5	1	1.5	2	2.5	3
y		2.125	3	2.375	1		-1	-0.125	

(a) Complete the table. [3]

(b) On the grid, draw the graph of $y = x^3 - 3x^2 + 3$ for $-1 \leq x \leq 3$.

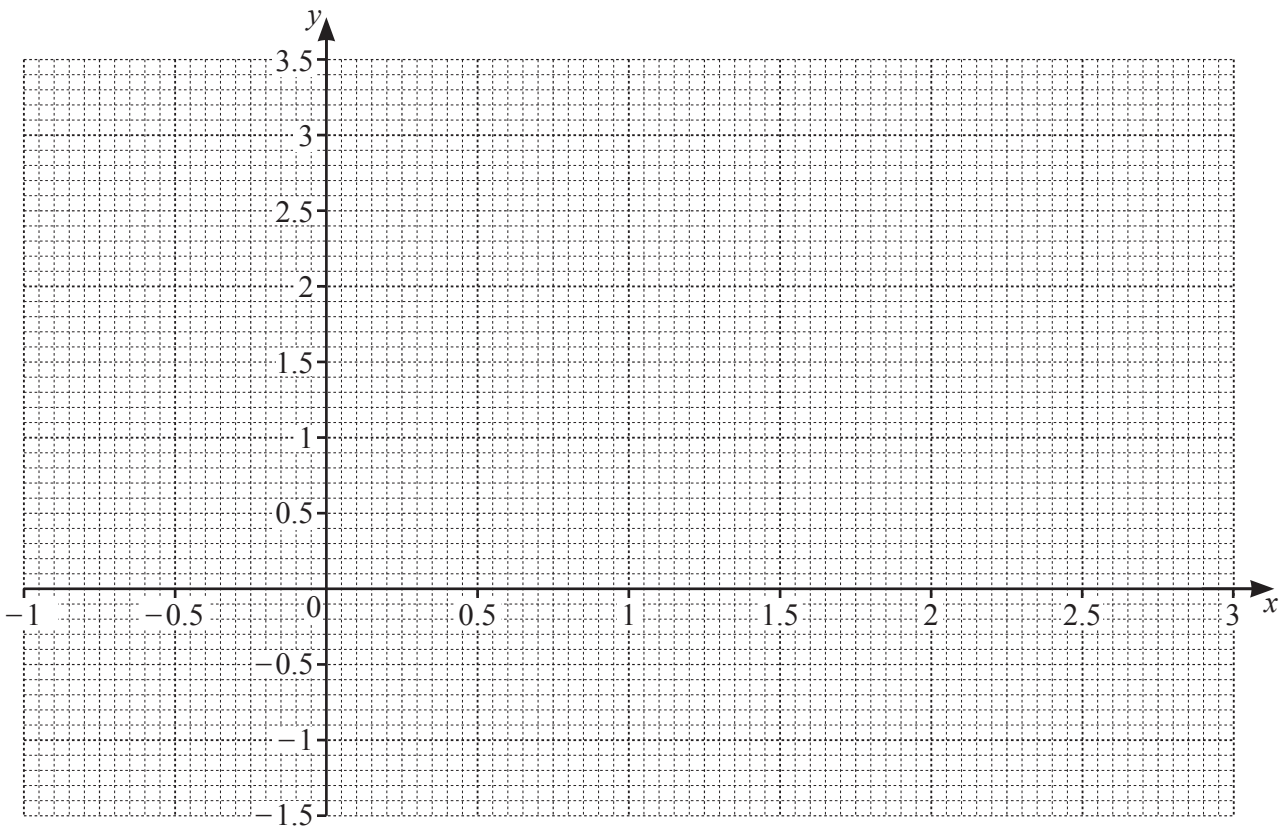

[4]

(c) By drawing a suitable straight line on the grid, solve the equation $x^3 - 3x^2 + x + 1 = 0$.

$x = \dots\dots\dots$ or $x = \dots\dots\dots$ or $x = \dots\dots\dots$ [4]

6 (a) Solve.



(i) $4(2x - 3) = 24$

$x = \dots\dots\dots$ [3]

(ii) $6x + 14 > 6$

$\dots\dots\dots$ [2]

(b) Rearrange the formula $V = 2x^3 - 3y^3$ to make y the subject.

$y = \dots\dots\dots$ [3]

(c) Show that $(2n - 5)^2 - 13$ is a multiple of 4 for all integer values of n .

[3]

(e) The energy of a moving object is directly proportional to the square of its speed.
The speed of the object is increased by 30%.
Calculate the percentage increase in the energy of the object.

$\dots\dots\dots$ % [2]

(d) The expression $5 + 12x - 2x^2$ can be written in the form $q - 2(x + p)^2$.

(i) Find the value of p and the value of q .

$p = \dots\dots\dots$, $q = \dots\dots\dots$ [3]

(ii) Write down the coordinates of the maximum point of the curve $y = 5 + 12x - 2x^2$.

($\dots\dots\dots$, $\dots\dots\dots$) [1]

(b)

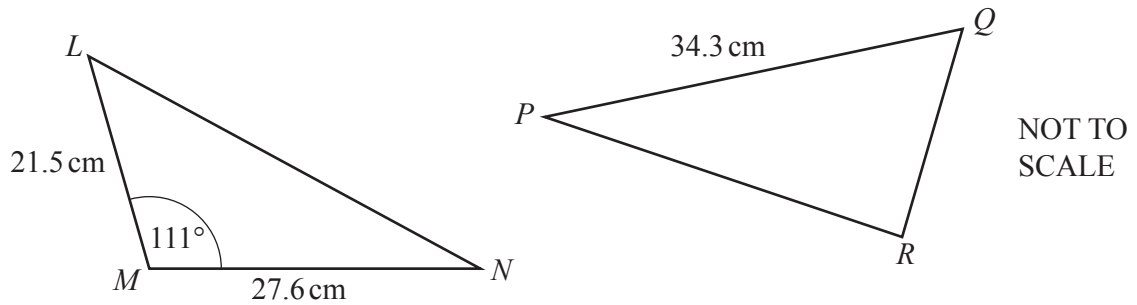

Triangle PQR has the same area as triangle LMN .
Calculate the shortest distance from R to the line PQ .

$\dots\dots\dots$ cm [3]

- 7 (a) The diagram shows a container for storing grain.



The container is made from a hemisphere, a cylinder and a cone, each with radius 2 m. The height of the cylinder is 5.2 m and the height of the cone is h m.

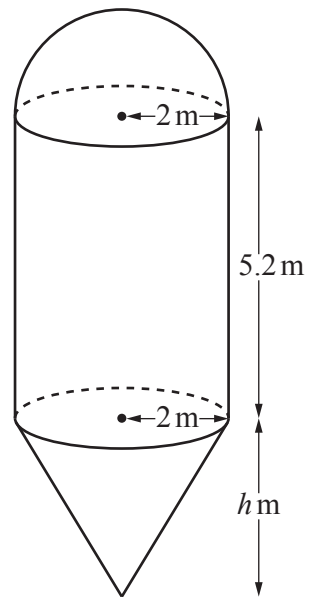

NOT TO SCALE

- (i) Calculate the volume of the hemisphere.
Give your answer as a multiple of π .

..... m^3 [2]

- (ii) The total volume of the container is $\frac{88\pi}{3} \text{ m}^3$.

Calculate the value of h .

$h =$ [4]

- (iii) The container is full of grain.
 Grain is removed from the container at a rate of 35 000 kg per hour.
 1m³ of grain has a mass of 620 kg.

Calculate the time taken to empty the container.
 Give your answer in hours and minutes.

..... h min [3]

(b)

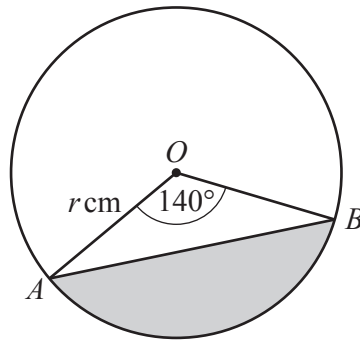

NOT TO
SCALE

A and B are points on a circle, centre O , radius $r \text{ cm}$.
 The area of the shaded segment is 65 cm^2 .

Calculate the value of r .

$r =$ [4]

8 (a) Kaito runs along a 12 km path at an average speed of x km/h.



(i) Write down an expression, in terms of x , for the number of hours he takes.

..... hours [1]

(ii) Yuki takes 1.5 hours longer to walk along the same path as Kaito.
She walks at an average speed of $(x - 4)$ km/h.

Write down an equation, in terms of x , and show that it simplifies to $x^2 - 4x - 32 = 0$.

[4]

(iii) Solve by factorisation.

$$x^2 - 4x - 32 = 0$$

$x = \dots\dots\dots$ or $x = \dots\dots\dots$ [3]

(iv) Find the number of hours it takes Yuki to walk along the 12 km path.

..... hours [2]

- (b) A bus travels 440 km, correct to the nearest 10 km.
 The time taken to complete the journey is 6 hours, correct to the nearest half hour.

Calculate the lower bound of the speed of the bus.

..... km/h [3]

- 9 (a) F is the point $(5, -2)$ and $\vec{FG} = \begin{pmatrix} -2 \\ 3 \end{pmatrix}$.



Find

- (i) the coordinates of point G ,

(.....,) [1]

- (ii) $5\vec{FG}$,

$\begin{pmatrix} \\ \end{pmatrix}$ [1]

- (iii) $|\vec{FG}|$.

..... [2]

(b)

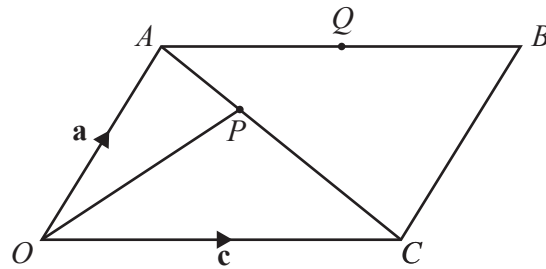

NOT TO SCALE

$OABC$ is a parallelogram.
 P is a point on AC and Q is the midpoint of AB .
 $\vec{OA} = \mathbf{a}$ and $\vec{OC} = \mathbf{c}$.

(i) Find, in terms of \mathbf{a} and/or \mathbf{c}

(a) \vec{AQ} ,

$\vec{AQ} = \dots\dots\dots$ [1]

(b) \vec{OQ} .

$\vec{OQ} = \dots\dots\dots$ [1]

(ii) $\vec{OP} = \frac{2}{3}\mathbf{a} + \frac{1}{3}\mathbf{c}$

(a) Show that O, P and Q lie on a straight line.

[2]

(b) Write down the ratio $OP : OQ$.
 Give your answer in the form $1 : n$.

$1 : \dots\dots\dots$ [1]

- 10 (a) Find the coordinates of the turning points of the graph of $y = x^3 - 12x + 6$.
You must show all your working.



(..... ,) and (..... ,) [5]

- (b) Determine whether each turning point is a maximum or a minimum.
Show how you decide.

[3]

11 (a)

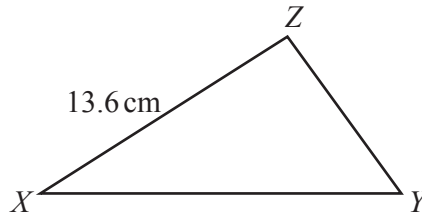
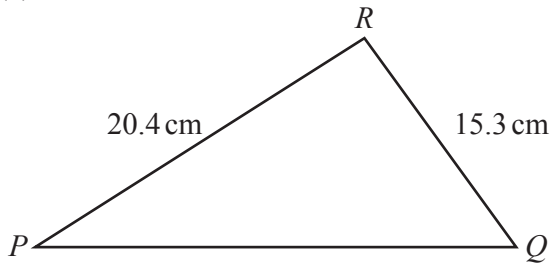

NOT TO SCALE

Triangle PQR is mathematically similar to triangle XYZ .

(i) Find YZ .

$YZ = \dots\dots\dots$ cm [2]

(ii) The area of triangle XYZ is 63.6 cm^2 .

Calculate the area of triangle PQR .

$\dots\dots\dots \text{ cm}^2$ [3]

(b) Two containers are mathematically similar.

The larger container has a capacity of 64.8 litres and a surface area of 0.792 m^2 .

The smaller container has a capacity of 37.5 litres.

Calculate the surface area of the smaller container.

$\dots\dots\dots \text{ m}^2$ [3]